

DEVELOPMENT OF FLOW RATE MEASUREMENT ON OPEN CHANNEL FLOW USING ULTRASONIC DOPPLER METHOD

Takashi Arimatsu*, Sanehiro Wada*, Hiroshige Kikura*, Masanori Aritomi*
and Michitsugu Mori**

*Research Laboratory for Nuclear Reactors, Tokyo Institute of Technology, 2-12-1 Ohokayama, Meguro-ku,
Tokyo, 152-8550 Japan, e-mail: arimatsu@2phase.nr.titech.ac.jp

**Tokyo Electric Power Company, 4-1 Egasaki-cho, Tsurumi-ku, Yokohama, 230-8510 Japan

ABSTRACT

This paper presents the velocity profiles and the accurate flow rate measurements on open channel flow using Ultrasonic Doppler method. In this study, the accurate flow rate was calculated by integrating the velocity distributions over the cross section. The flow rate measurements were carried out on three different conditions. The flow rate measured by this method was compared with the flow rate measured by Electromagnetic flow meter and the results show the errors were less than 6%.

Keywords: ultrasonic Doppler velocity profiler, open channel, velocity profile, multiline measurement, flow rate

INTRODUCTION

Many instruments, working on a variety of principles, have been developed to measure velocity profiles in an open channel. The information of liquid velocity distribution over the cross section is necessary for the flow physic study. For the measurement in an open channel, many attempts [1] have been conducted such as hot film anemometry [2] and Laser Doppler anemometry [3]. However, those devices provided only the local information in a single point. The multi-dimensional properties such as velocity profile and time-dependent flow rate is still difficult to measure simultaneously. This limitation becomes worse in the case of the measurement in the application with time dependent cross-sectional area change, i.e. the measurement in the river with sand bottom and with sludge accumulation.

Recently Ultrasonic Velocity Profiler (UVP) has been developed and applied to measure local instantaneous flow properties along the measuring line [4][5]. Thus, it is able to improve the flow metering performance and to be applied for a transient flow rate measurement. In this measuring system, flow rate was calculated using the velocity profiles that were obtained by UVP. Wada et al. [6] applied three transducers to evaluate the more accurate time-dependent liquid flow rate in developing regime in vertical circular pipe. The results show that the errors were less than 1%. Tezuka et al. [7] investigated the effect of the inner surface roughness of a pipe on the velocity profiles and flow rate measurement. They showed that the error was up to 8%. However, the assumption of velocity profiles was required to measure the time-dependent flow rate.

According to the available literatures, the multi-line measurement has been conducted mostly in the pipe flow where the cross-section area is constant. From this point of view, the objective of this paper is to develop the multi-line flow rate measurement using Ultrasonic Doppler in an open channel where the cross-section area is varied in time domain.

EXPERIMENTAL APPARATUS

The experimental apparatus are illustrated in Fig.1. The experiment was carried out in the open channel. The open channel was made of acrylic resin, with length 3200mm, height 200mm, and width 100mm. The flow rate in open channel was adjusted by the flow rate in bypass using valve. The water level was adjusted by the supplied flow rate into open channel and the height of dam at the downstream end of the channel. The height of dam was 50mm in this experiment. Due to the area expansion at the entrance, the water level fluctuation would be induced. In this case, the surface flow was kept stable by the rectifier at the entrance of the open channel. The flow rate in open channel was monitored by electromagnetic flow meter (MGK1010K, Tokyo Keiso).

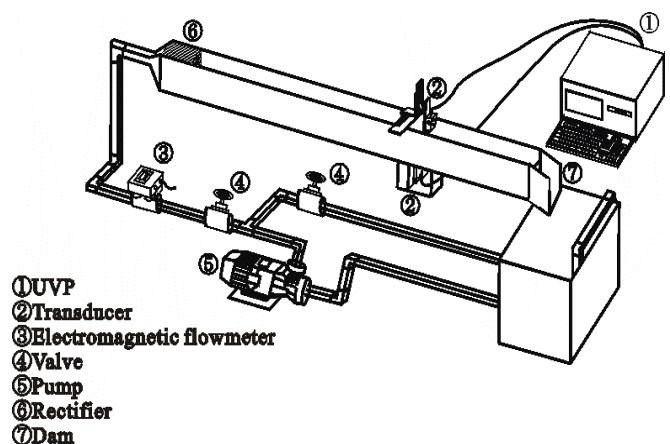

Fig.1 Experimental apparatus

VELOCITY MEASUREMENT

The measuring system consists of the ultrasound velocity profile monitor (UVP model X3-Psi, Met Flow). The working frequency of the ultrasonic transducer is 8 MHz. The transducer was set up at the free surface with an angle of 70 ° with respect to the mean flow parallel to the open channel axis. The nylon micro tracer particles (WS-200P, Daicel Hüls) are utilized to trace the liquid velocity. Their average diameter was 80 μ m. Experiments were carried out at atmospheric temperature, water temperature was kept at 22 ° using the sub cooler. In order to indicate flow condition, liquid velocities along the centre-plane at the position of 100mm, 200mm, 400mm, 800mm, 1600mm, and 2400mm were measured. Furthermore, liquid velocity distribution over the entire cross-section was also measured at the position of 2400mm downstream from the entrance with 31 measuring points in the span wise direction.

In order to clarify the effect of transducer position, the comparison of the velocity profiles obtained from upper and lower position of the channel was performed. The measuring configuration was shown in Fig.2. Transducer for lower position was placed in small acrylic resin box below the channel. The space of the box was filled with the water and covered with acrylic resin wall with 2 mm thickness. For the upper position, transducer was placed at the free surface with an angle of 70 ° with respect to the mean flow direction. The accuracy measurement of Ultrasonic Doppler method using both upper and lower transducer position was also verified by comparing with the standard device, Electromagnetic Current Meter (VP1000RT and VPT-400-09PS, KENEK). The comparison was performed at the distance of 2100 mm from the entrance on the centre plane of the channel.

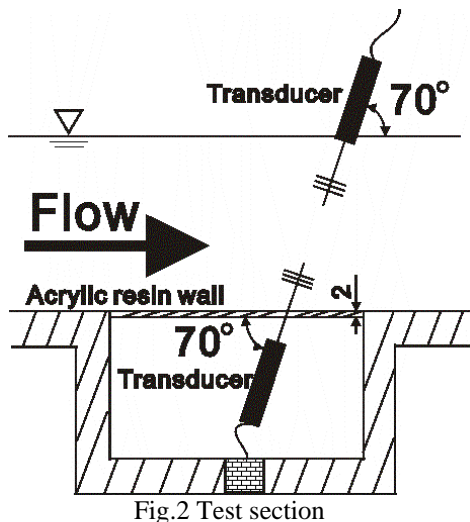

Fig.2 Test section

FLOW RATE MEASUREMENT

It is known that the variation of transducer position and angle affects directly to the measurement of velocity distribution and water level. In this case, liquid velocity distribution and water level shall be reported by changing the transducer position in traverse direction with the constant measuring angle.

By using the obtained liquid velocity distribution, the liquid flow rate can be calculated by integrating the local velocity distributions over the entire cross section using the upper transducer. The velocity at the wall was treated as no-slip condition. The flow rate was calculated by Eq. (1). [8]

$$Q = \sum_{p=1}^m \sum_{l=1}^n \frac{\Delta x \cdot \Delta z}{4} (v_{p,i} + v_{p,i+1} + v_{p+1,i} + v_{p+1,i+1}) \quad (1)$$

- m : Number of measurement points on cross section,
- n : Number of measurement cubic in axial direction,
- l : Spatial resolution in span wise direction,
- z : Spatial resolution in vertical direction,
- v : Local time-averaged liquid velocity

The measurements were carried out on steady (normal condition) and unsteady condition (condition A and B). The unsteady flow was generated, in this case, by applying the solid obstacle to disturb the flow. The utilized obstacle that was made of acrylic resin has the dimension of 30x50x200 mm³. The obstacle configuration for condition A and B is illustrated in Fig. 3.

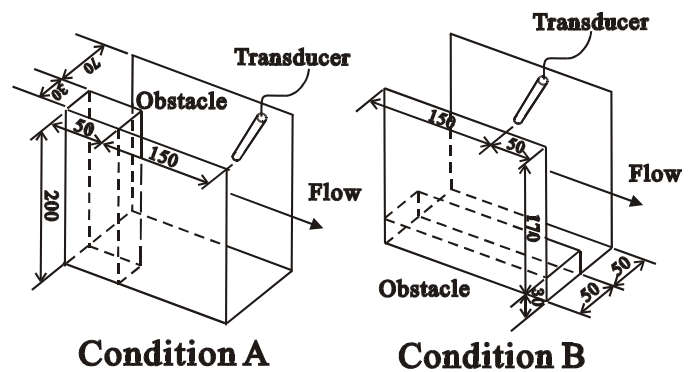

Fig.3 Experimental condition A and B

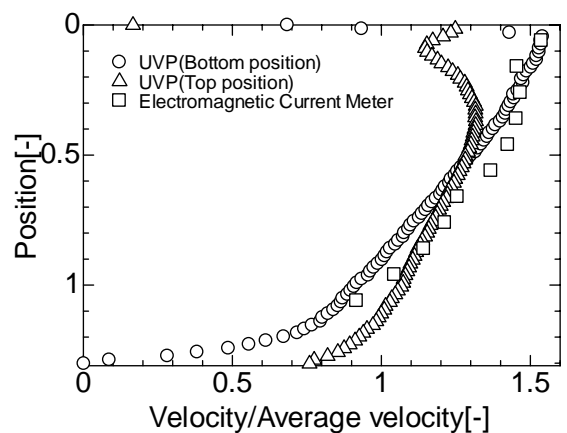

Fig.4 Liquid velocity distribution between upper and lower position of transducer comparing with Electromagnetic current meter

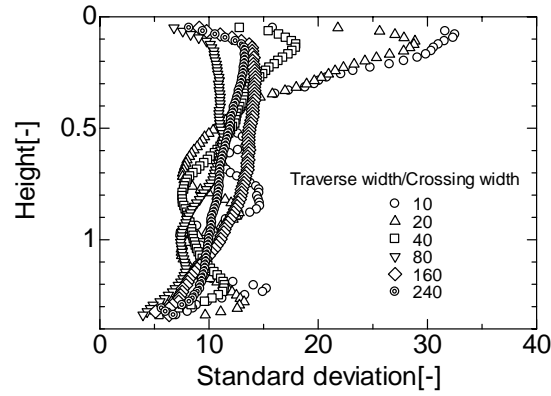

Fig.5 Standard deviation of profiles

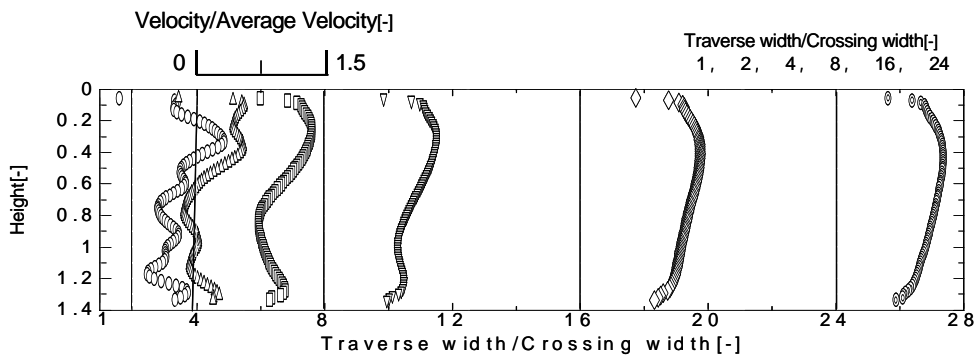

Fig.6 Velocity distributions on the centre-plane

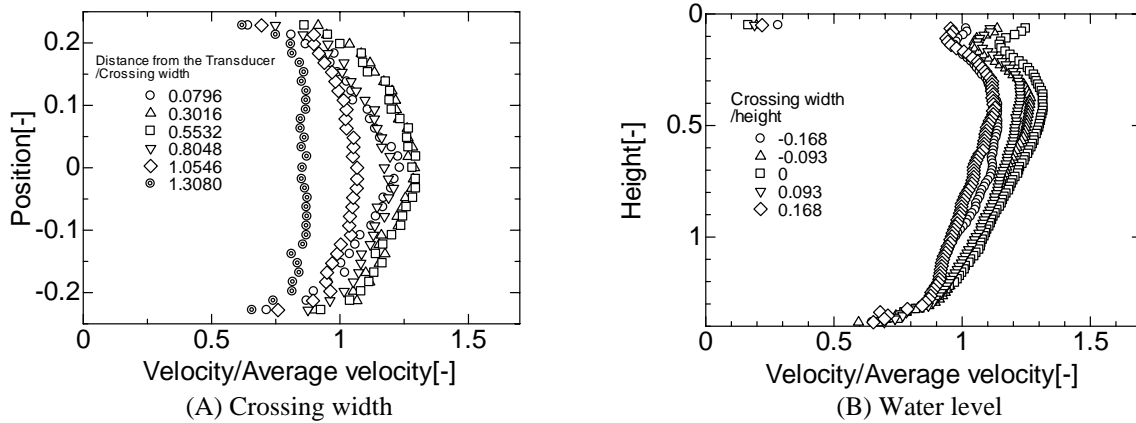

Fig.7 Velocity distributions on normal condition

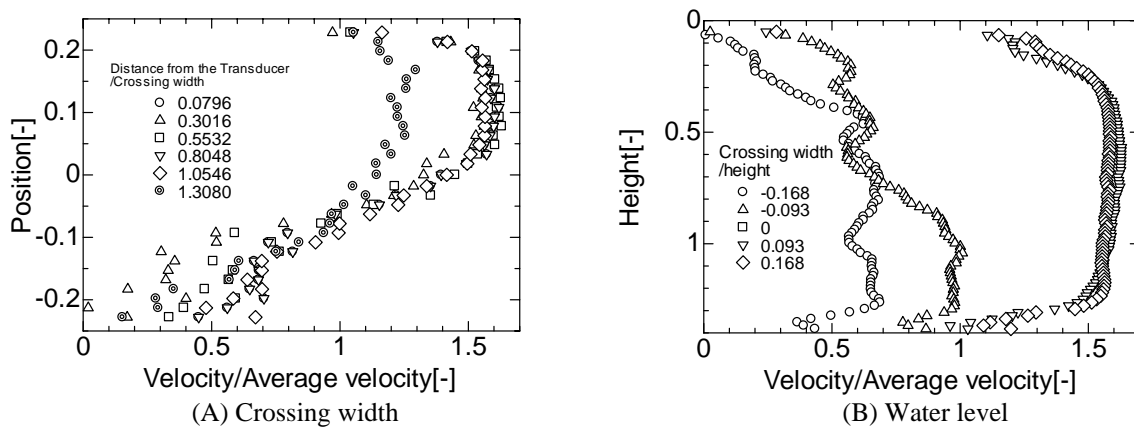

Fig.8 Velocity distributions on condition A

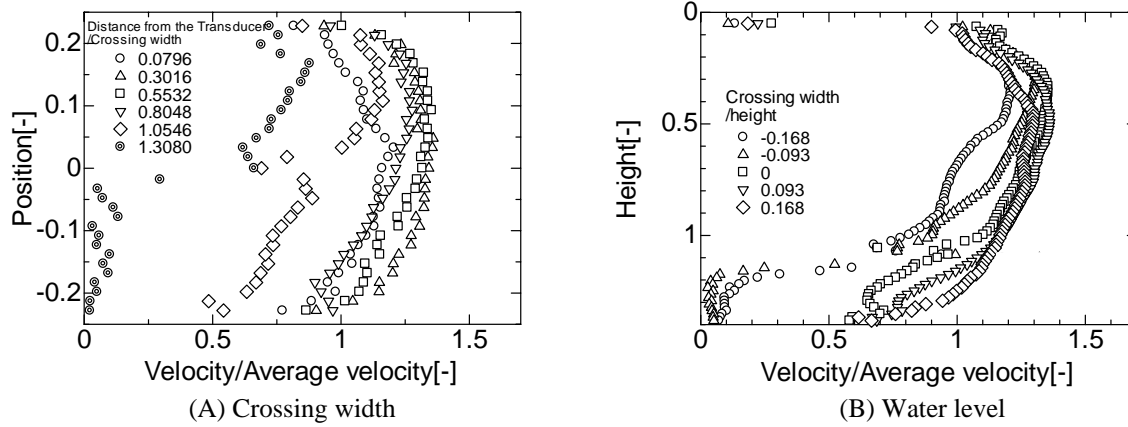

Fig.9 Velocity distributions on condition B

RESULTS AND DISCUSSION

The results of mean velocity distributions obtained by UVP and Electromagnetic current meter were shown in Fig.4. The good agreement was found for lower transducer position, while the slightly deviation was observed for the upper transducer position. The larger deviation for the upper transducer comparing with the lower one can be explained by the water level fluctuation of the free surface near the ultrasonic transducer.

Fig.5 shows the standard deviation of velocity profiles on the centre-plane. It can be seen that the scattered velocity was enhanced particularly near the entrance, water surface and bottom regime. Fig.6 shows the velocity distributions on the centre-plane. It can be seen that the velocity distributions near the entrance has no exactly flow pattern. Furthermore, the fully-developed velocity distribution is observed at the position of 1600mm downstream from the entrance quite far from the inlet.

The flow rate measurement was performed at the distance of 2400mm from the entrance to avoid the unsteady condition near the entrance. Fig.7 shows the velocity distributions in span-wise direction (Fig.7 (A)) and the variation of water level (Fig.7 (B)) under normal condition. It can be seen the small deviation between each profile referring to the steady condition. Similar to Fig.7, the results of unsteady condition A and B is illustrated in Fig. 8 and Fig. 9 respectively. As the results, large deviations are observed between each profile due to the high unsteady level generated from the obstacle.

Table 1 shows the result of the liquid flow rate calculation according to Eq. (1) and compared with the standard device using electromagnetic flow meter. The overall deviation is less than 6 %. These errors probably cause by the water level fluctuation on the free surface. This can be seen from the larger deviation of steady normal condition and unsteady condition B comparing with unsteady condition A. Therefore, it is possible to measure not only the steady flow rate but also the unsteady flow rate.

Table 1. Result of the flow rate measurements

Condition	Electromagnetic flowmeter (l/min)	This method (l/min)	Error (%)
Normal condition	56.7	54.4	- 4.1
Condition A	55.3	54.3	- 1.8
Condition B	55.0	52.0	- 5.5

CONCLUSION

Ultrasonic Doppler method was applied to the open channel flow. The information of velocity distribution and water level in term of the transducer position and its angle were obtained. The velocity distributions obtained by UVP were applied to calculate the liquid flow rate particularly under the unsteady condition. The results show that it is possible to measure not only the steady flow rate but also the unsteady flow rate accurately. Finally, the effect of water level fluctuation near the transducer is revealed. In this case, some measurement correction is required to minimize the overall error generated during the measurement.

REFERENCES

1. U.Lemmin , T.Rolland, 1997, Acoustic Velocity Profiler for laboratory and field studies, *J. Hydr.Engrgl.*, pp. 1089-1098.
2. M. Bayazit,1976, Free surface flow in a channel of large relative roughness, *J. Hydr.Res.*, 14(2), pp. 115-126.
3. I. Nezu , W.Rodi, 1986, Open channel flow measurement with a Laser Doppler Anemometer, *J. Hydr.Engrg.*, 112(5), pp. 335-355.
4. Y. Takeda, 1987, Measurement of velocity profile of mercury flow by ultrasound Doppler shift method, *Nucl. Technol.*, 79, pp. 120-124 .
5. Y. Takeda, 1995, Velocity profile measurement by ultrasonic Doppler method. *Exp. Therm. Fluid Sci.*, 10, pp. 444-453.
6. S. Wada, et al., 2004, Development of pulse ultrasonic Doppler method for flow rate measurement in power plant (Multilines flow rate measurement on metal pipe), *Nuc. Sci. Technol.*, vol. 41, No. 3, pp. 1-8.
7. K. Tezuka, et al., 2003, Development of flow rate and profile measurement using ultrasonic Doppler method (17) Effects of pipe elbows on swirl and Reynolds number changes" *Fall Meeting of the Atomic Energy Society of Japan*, F43, pp.24-26.
8. S.Wada, et al., 2003 , Environmental flow mapping using ultrasonic Doppler method, *FLUCOME*, 7th,CD-R paper No.ID-85, pp.1-6.