

ELBE RIVER MODEL: UVP FLOW MAPPING

Vojtech Bares¹ and Prof. Vojtech Broza²

¹ Doctorand, Czech Technical University in Prague, Faculty of Civil Engineering, Laboratory of Ecological Risks in Urban Drainage, bares@lermo.cz

² Professor, Czech Technical University in Prague, Faculty of Civil Engineering, Department of Hydraulic Engineering and Hydraulic Structures, milecova@fsv.cvut.cz

Keywords: open channel flow, velocity distribution, flow measurements, hydraulic structures, flow simulation

ABSTRACT

The aim of the study was to appreciate the navigation conditions at the planed Elbe river water work Prelouc. For the flow field investigation the physical and mathematical modeling methods were used. The main important role in the physical modeling of navigation conditions in hydraulic models plays the flow field determination, especially in water way branch areas and moreover in significant water intakes. The criteria for navigation safety reviewing are mostly the vertical velocity components to the to the crafts movement direction, determined in the range of 0.15-0.4 m.s⁻¹, which in hydraulic model scale correspond to values in order of 10⁻² m.s⁻¹. Moreover, for accurate measurement of the velocity components the ultrasonic Doppler method was used. Furthermore, the physical modeling results were used for the mathematical model calibration and verification.

1. INTRODUCTION

Elbe river navigable length in Czech Republic is 230km. Also it is a natural connection to the European waterways net.

Recently the attention is focused on navigation conditions improvement and moreover on the waterways modernization. The manful reality is, that the Elbe water way consists mostly from low dams cascade, which independently on river flow provide requisite water level, excluded the lower rich of the river (more than 30km) by the Czech – German border. Furthermore, at some water structures, built 60 years ago, the adjustments are needed.

The attention of the office for development water ways (The water ways directorate) mostly focused on above mentioned problems. Besides projecting works in the lower rich of the river (Strekov - Czech – German border), the navigation conditions improvement of the upper rich (Pardubicko) is arranging. Therefore the new navigation step realization is prepared. It consists in use of gated weir (included the head water section), with the new navigation channel (length 3.2km) in right side line.

The total slope 8.5m is at the end part of the channel overcoming by two lock chambers. The water energy should be used in water power plant with total discharge of 75 m³.s⁻¹.

The conception method of solution was influenced by environmental and/or culture – historical points of view. Since the original weir with the water power plant from 1928 is an architectural memory, and moreover in the neighborhood of the planned water structure are ecologically protected areas, the solution with the right side line is taken as a compromise. In

the frame of the proposed conception the most sensitive localities from the navigation conditions view are:

- A the right side channel branch from dam reservoir,
- B the channel section upstream the lock chambers with the water power plant inlet
- C the section downstream the navigation chambers influenced by outlet from water power plant
- D the navigation channel and Elbe river junction.

2. METHODS

For the navigation conditions in above mentioned river parts clarification the investigation by physical and mathematical modeling (1D, 2D) was realized.

2.1 Experimental apparatus

The experiment was done in two independent hydraulic models:

- a) the navigation channel branch from the dam reservoir – model H (Figure 1).
- b) the section including water power plant, lock chambers, channel section under the lock chambers, water power plant outlet and the navigation channel and Elbe river junction – model K+D (Figure 2).

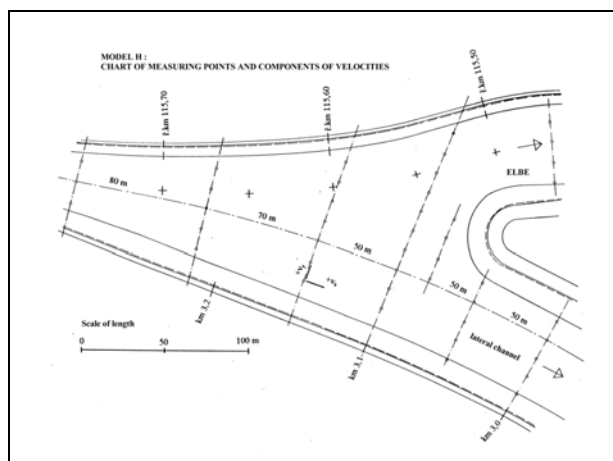

Figure 1 Model H layout

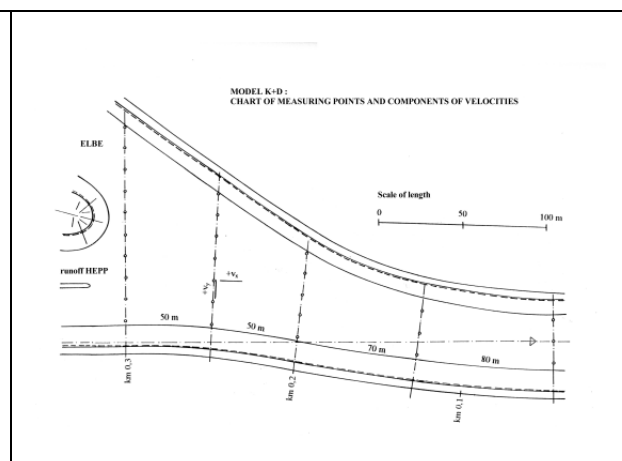

Figure 2 Model K+D layout

Moreover, the main attention was concentrate at velocity field measurement numerical calculation in studied areas.

Hydraulic models were constructed in the model scale of 1:50, velocity scale of 1:7.071, discharge scale of 1:17678 and surface roughness 1:1.93. The model dimension were constructed in range of 12x4m or 26x4m, respectively. The measuring weirs were clapped at the models inlet and outlet. The water level quota was measured with point square.

Several different operations conditions of water power plant and various flow stages, which influence entrance and exit from the navigation channel, until the maximal navigation throw-flow $Q_{\max} = 277 \text{ m}^3 \cdot \text{s}^{-1}$ (in model scale $Q_{\max \text{ model}} = 15.67 \text{ l} \cdot \text{s}^{-1}$).

The velocity vectors were investigated in the net of 77 measuring points placed in three levels below the water level, which correspond to 462 values velocity components in the x, y co-

ordinates. The values were measured with micro propeller meters NIXON and UVP monitor (Ultrasonic Velocity Profile Monitor), Met-Flow S.A. Moreover we used six ultrasound probes with basic frequency $f_0 = 4\text{MHz}$. In each point three probes for longitudinal velocity components and three probes for lateral speed components at three independent levels (Figure 3) Each probe was 100mm away the measuring points, which corresponds to the 65th point in the ultrasound probe measuring line. The velocity vector average components were obtained from continual measurement for the duration of 45 s.

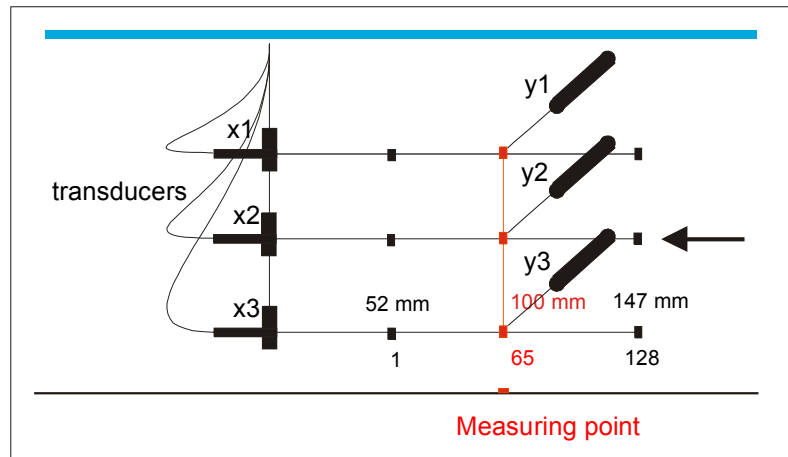

Figure 3 The probes position in the measuring point

For better signal obtain the micro-particles PVC – NERALIT 581 (measuring weight $\rho = 1350 \text{ kg.m}^{-3}$ and $d_{50} = 0.15 \text{ mm}$) were added into the flowing water.

2.2 Mathematical model

For the mathematical simulations the software SHALLOW was used. This software was developed in the Department of Hydraulic Engineering and Hydraulic Structures, CTU for 1D and 2D steady flow simulations with free water surface in open channels. Moreover, this model applies finite elements method (FEM) and stem from the vertical integrated Reynolds equation scheme for turbulent flows, known as “shallow water equations”.

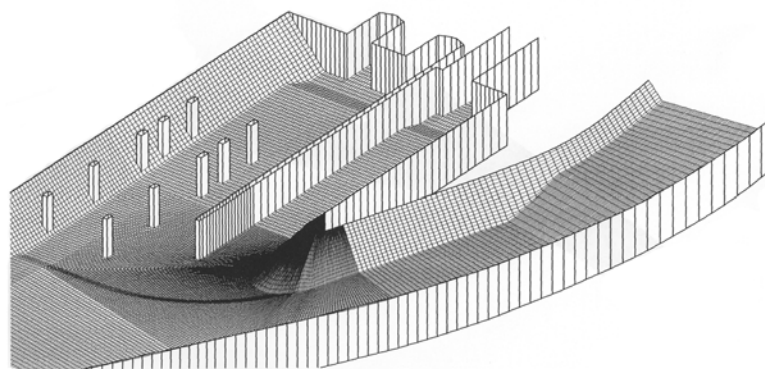

Figure 4 Geometry of mathematical model K+D

For the turbulence modeling, the constant effective viscosity principle was used. This principle is dedicated with use of algebraic relations for the turbulent dispersion coefficient, based on analogy between dynamics and mass transfer in turbulent flows.

3. RESULTS

In both models the water flows conditions modeling approved the suggestion, that the project solving ensure good navigation conditions.

Furthermore, in the fairway of all the modulated conditions, the average longitudinal speed did not exceeded $1.9 \text{ m}\cdot\text{s}^{-1}$ and the average lateral velocity did not exceed $0.2 \text{ m}\cdot\text{s}^{-1}$ ($0.3 \text{ m}\cdot\text{s}^{-1}$). Therefore the critical clauses for navigation Czech Standards were not exceeded.

The water power plant plays a positive role in the velocity field shape in the entrance and exit of the navigation channel, where lower lateral velocity components were measured (Figure 6, Figure 8). In contrast, there was shown the negative effect in the water power plant inlet. In consequence of these findings, the geometry changes of the upper docks were brought in.

The UVP method obtained values were also used for the mathematical model calibration and verification. With this model were considered other flow conditions. The measured and calculated data comparison is shown in Figure 5 – Figure 8. The agreement was found in very high level, just in the higher gradients of longitudinal velocity area the deviations in lateral components were observed.

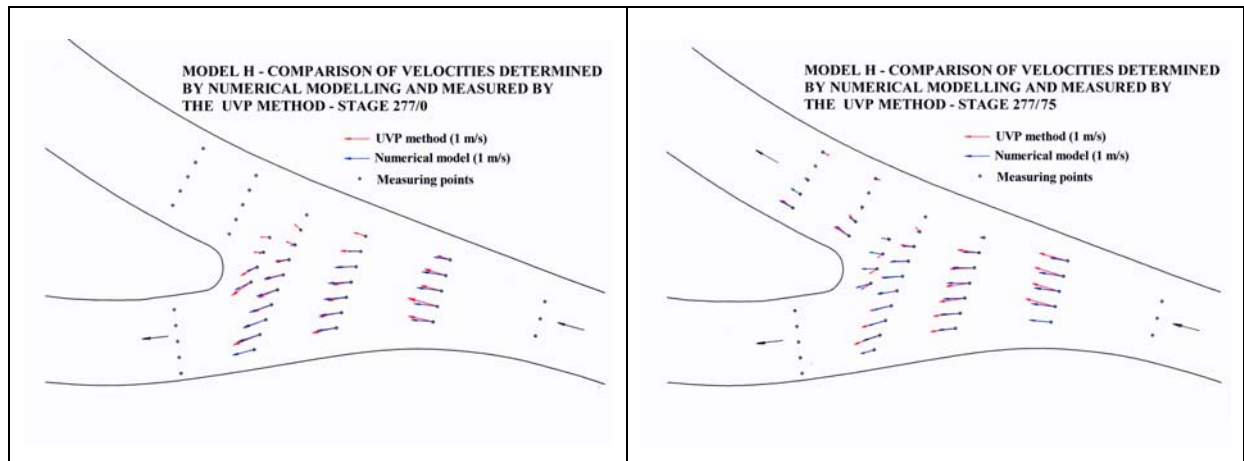

Figure 5 Flow field model H – stage 1

Figure 6 Flow field model H - stage 2

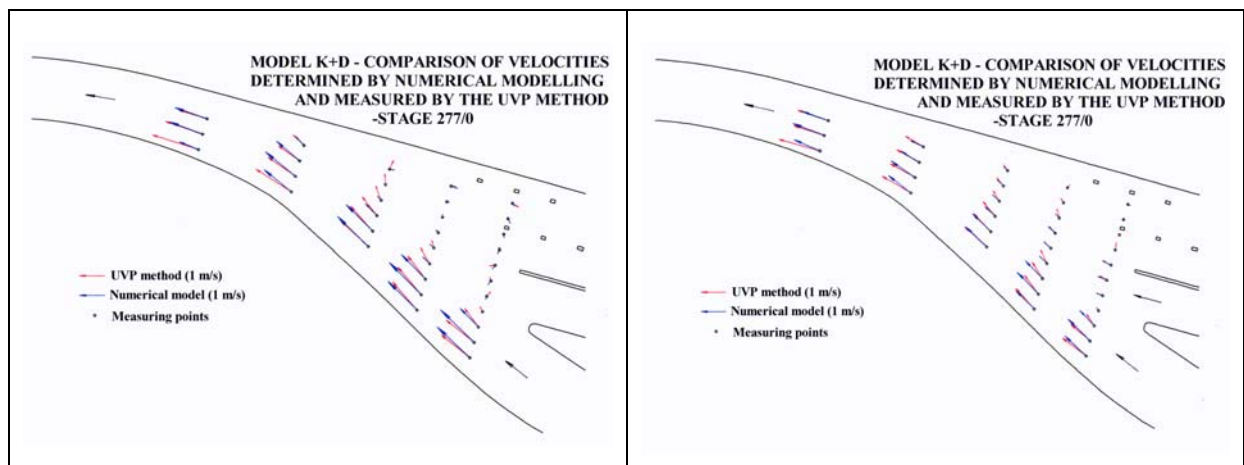

Figure 7 Flow field model K+D – stage 1

Figure 8 Flow field model K+D – stage 2

4. CONCLUSIONS

The flow field investigation with small values of speed components is common problem, which follows the evaluation of safety conditions of navigation. The Ultrasonic Doppler Method is in this cases very applicable and rationally useful method. Moreover, in the combination with a mathematical modeling, this method allowed to obtain correct image about the water construction system.

REFERENCES

- Bares V.** (1999), *Gated weir at Elbe River in Prelouc – stage solution*, Diploma thesis, CTU - Prague
- Broza, V., Medricky, V., Valenta P.** (2000). *Modelovy vyzkum noveho plavebniho sutpne Prelouc*, Stavebni obzor 7/2000, pg. 204-211
- Lemmin, U., Rolland T.** (1997). *Acoustic Velocity Profiler for Laboratory and Field Studies*. J. Hydr. Engrg., ASCE, Dec 1997, 1089-1098.
- Metflow** (2000). *UVP Monitor – Model UVP-XW*, Users guide, Met-flow SA, Lausanne, Switzerland
- Takeda, Y.** (1995). *Instantaneous Velocity Profile Measurement by Ultrasonic Doppler Method*, JSME International Journal, 8-16
- Takeda, Y.** (1997). *Ultrasonic Doppler Method for Fluid Flow Measurements – Principle and its Applications*. Bulletin of the Research Laboratory for Nuclear Reactors, special issue no. 2, 1-14