

## APPLICATION OF ULTRASOUND DOPPLER VELOCIMETRY TO FLOWS OF HOT METALLIC MELTS

S. Eckert<sup>1</sup>, G. Gerbeth<sup>1</sup>, V.I.Melnikov<sup>2</sup>, C.-H. Lefhalm<sup>3</sup>, J. Knebel<sup>3</sup>

<sup>1</sup>Forschungszentrum Rossendorf, P.O.Box 510119, D-01314 Dresden, Germany, s.eckert@fz-rossendorf.de

<sup>2</sup>University Nishni-Novgorod, Minin street 24, 603 600 Nishni-Novgorod, Russia, melnikov@nntu.sci-nnov.ru

<sup>3</sup>Forschungszentrum Karlsruhe, P.O.Box 3640, D-76021 Karlsruhe, Germany, lefhalm@iket.fzk.de

Keywords: ultrasonic Doppler velocimetry, acoustic wave guide, liquid metals, flow velocity measurement, two-phase flow, bubbles

### ABSTRACT

During the last decades the Ultrasound Doppler Velocimetry (UDV) became a very powerful tool to measure the velocity structure of liquid flows. Because of the ability to work in opaque fluids and to deliver complete velocity profiles in real time it becomes very attractive for liquid metal applications. But, in case of hot metallic melts the user is confronted with a number of specific problems: First of all, the application of the ultrasonic transducers is usually restricted to maximum temperatures of 150°C. The transmission of a sufficient amount of ultrasonic energy from the transducer to the fluid has to be guaranteed. Here, the acoustic coupling and the wetting conditions have to be considered as important issues. Moreover, the flow has to be seeded with reflecting particles to obtain Doppler signals from the fluid.

The feasibility of velocity profile measurements by UDV has already been demonstrated for low temperature liquid metals as mercury (Takeda, 1987) and gallium (Brito et al., 2001). Now, first successful measurements in liquid sodium at 150°C are published by Eckert & Gerbeth (2002). We will present mean profiles of a sodium flow in a rectangular duct exposed to an external, transverse magnetic field. To demonstrate the capability of UDV the transformation of a well-known turbulent, piston-like profile to a M-shaped velocity profile with growing magnetic field strength was observed.

An integrated ultrasonic sensor with acoustic wave guide has been developed to overcome the limitation of ultrasonic transducers to temperatures lower than 200°C. This sensor can presently be applied at maximum temperatures up to 600°C, but an extension up to 800°C can reasonably be expected. In this presentation we show some experimental results obtained in flows with eutectic PbBi at temperatures up to 350°C and in a CuSn alloy up to 620°C.

US frequency	4 MHz
Doppler angle	70°
Pulse repetition rate	6700 Hz
Measurable depth	175 mm
Bursts per profile	128
Velocity resolution	9 mm/s
Number of gates	140
Number of profiles	256
Spatial resolution in sodium	1.25 mm

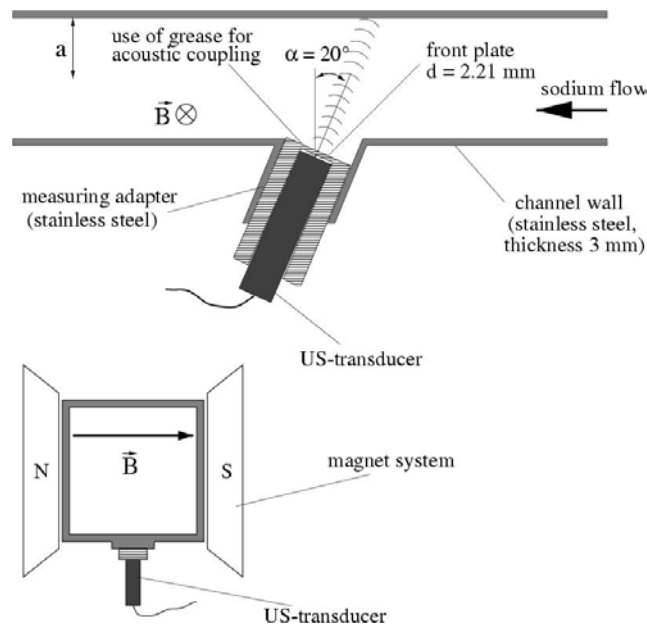
**Table 1. Set of system parameters adjusted in the sodium experiment**

## 1. VELOCITY MEASUREMENTS IN LIQUID SODIUM

### 1.1 Experimental set-up

To demonstrate the capabilities of the UDV technique with respect to the applicability for sodium flows, we determined velocity profiles of a MHD channel flow exposed to a homogeneous, transverse magnetic field. We will give here a brief summary of our measurements and refer the reader to Eckert & Gerbeth (2002) for further details.

The experiments were performed at the sodium loop, NATAN, of Forschungszentrum Rossendorf (FZR). The facility operates with a sodium flow in the temperature range between 120°C and 350°C. An electromagnetic pump is used to generate the mean flow with maximum velocities of about 1.7 m/s in a square test section of  $44 \times 44 \text{ mm}^2$ . The horizontal test section is equipped with a homogeneous transverse magnetic field over a length of 1100 mm. For all variations of the magnetic field strength the liquid flow rate was kept constant.



**Figure 1. Schematic view of the arrangement of the sodium experiment at FZR**

The velocity profiles were measured in the direction perpendicular to the magnetic field lines. As shown in Figure 1 the US transducer was installed inside a cylindrical measuring adapter with an angle of  $70^\circ$  with respect to the mean flow parallel to the channel axis. Silicon grease was used to achieve the acoustic coupling between US transducer and the adapter wall. The front plate of the adapter is machined stainless steel with a thickness of 2.21 mm. To guarantee a sufficient transmission of US energy into the flow, the adapter surface must be well wetted by the liquid sodium. For this reason both sides of the adapter front plate were polished. The outer surface that would be in direct contact with the liquid metal was cleaned using phosphoric acid.

The DOP2000 (Signal Processing Lausanne) was used to carry out the velocity measurements. The US transducers are 4 MHz probes of a high temperature series (TR40405). The application range for this transducer is limited to maximum temperatures of 150°C (long term load) and 200°C (short term load), respectively. The measurements were performed at sodium temperatures of 145°C which was carefully controlled by a thermocouple in the vicinity of the measuring domain. The parameter sound velocity was

corrected according to the actual value of the temperature. Taking into account temperature fluctuations of about  $\pm 1$  K the resulting uncertainties in the determination of the measuring depth due to the corresponding sound velocity modifications were about 0.1 mm.

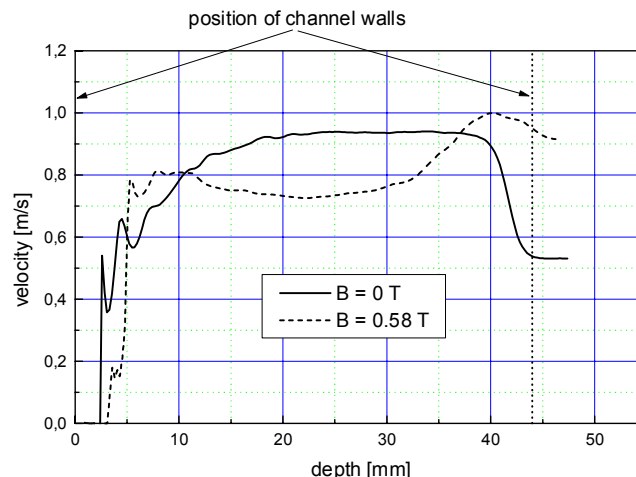
The device parameter configuration used in the experiments is shown in Table 1. The mean velocity profiles were calculated averaging 256 single profiles corresponding to a measuring time of about 5.6 s.

## 1.2 Results of the velocity measurements

Two examples of velocity profiles measured with and without magnetic field, respectively, are displayed in Figure 2. The effect of the magnetic field on the flow structure can be clearly detected. However, the occurrence of some artefacts becomes obvious:

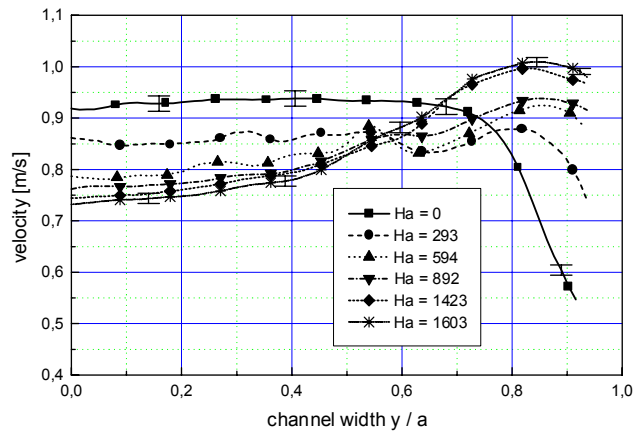
An inherent shortcoming of the UDV is the ringing effect of the US transducer that follows immediately after the emission of the pulse. It results in a saturation of the transducer preventing reliable measurements at depths just a few mm behind the surface of the transducer. In the present case additional perturbations arise by the influence of the adapter front wall because the US waves travelling also inside this wall contribute to the saturation of the piezoelectric element.

At a depth of 44 mm corresponding to the location of the opposite channel wall we do not find the velocity going to zero. Multiple reflections in the vicinity of the channel wall are considered to be the reason for this artefact. Because of this bias the velocity profiles have been truncated. The maximum negative velocity gradient measured in the boundary layer was chosen as criterion for truncation.



**Figure 2. Measured raw profiles of the velocity of the sodium duct flow with and without applied transverse magnetic field**

Figure 3 shows mean velocity profiles of the sodium duct flow obtained at a Reynolds number of about 56700 for variations of the Hartmann number, i.e. the magnetic field strength. In the case without magnetic field a velocity profile as known for turbulent channel flows was detected. A significant modification of the velocity structure can be observed if the flow is exposed to the transverse magnetic field. In the end regions of the pole faces the resulting electromagnetic force is not homogeneous in the cross-sectional area leading to a M-shaped profile of the velocity [4]. The development of such a M-shaped profile with increasing magnetic field can be clearly observed in Figure 3.



**Figure 3. Effect of a transverse magnetic field on the mean velocity profiles in a turbulent sodium duct flow**

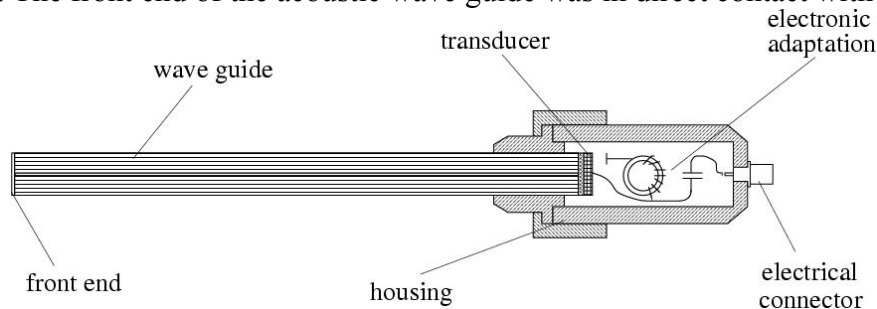
## 2. VELOCITY MEASUREMENTS BY MEANS OF AN ULTRASONIC SENSOR WITH INTEGRATED ACOUSTIC WAVE GUIDE

### 2.1 Sensor concept

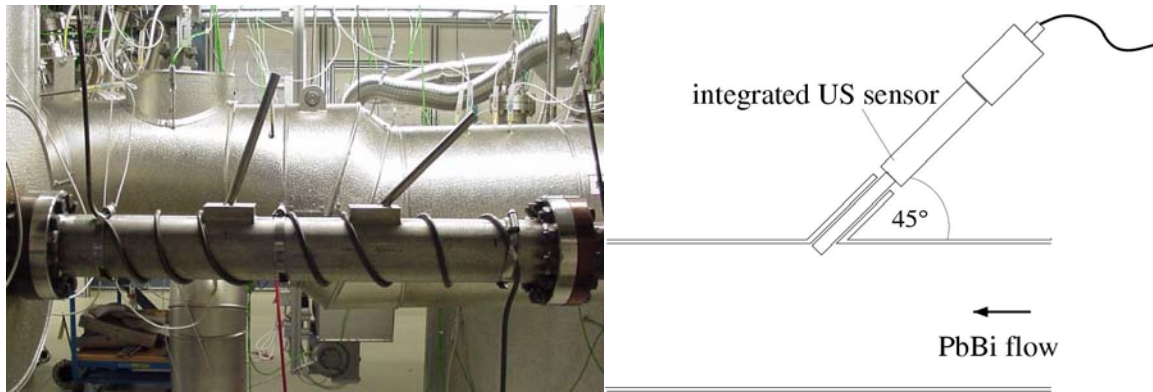
To overcome the thermal restrictions of the existing US transducer an integrated ultrasonic probe consisting on a wave guide and a piezoelectric transducer equipped with electronic components and a stainless steel housing was developed by the University of Nishni-Novgorod in collaboration with FZR (see Fig. 4). The acoustic wave guide is fabricated from a stainless steel foil with a thickness of 0.1 mm and a length of 200 mm which is wrapped axially around a capillary tube. The wave guide has an outer diameter of 7.5 mm. The wave guide was closed at the front end by means of laser beam welding. The piezoelectric element is welded directly on the rear end of the wave guide. The working frequency of the ultrasonic transducer is 4 MHz.

### 2.2 PbBi-channel flow

The THESYS loop of the KALLA laboratory of the Forschungszentrum Karlsruhe (FZK) focuses on the development and application of fundamental lead-bismuth technologies. At the THESYS loop velocity profiles of a eutectic PbBi flow (Pb44Bi56,  $T_{\text{melt}} = 125^{\circ}\text{C}$ ) in a round tube ( $\varnothing 60 \text{ mm}$ ) were successfully obtained by means of the integrated sensor. As shown in Fig. 5 the sensor is installed in a measuring port with an inclination of  $45^{\circ}$  with respect to the tube axis. The front end of the acoustic wave guide was in direct contact with the flow.

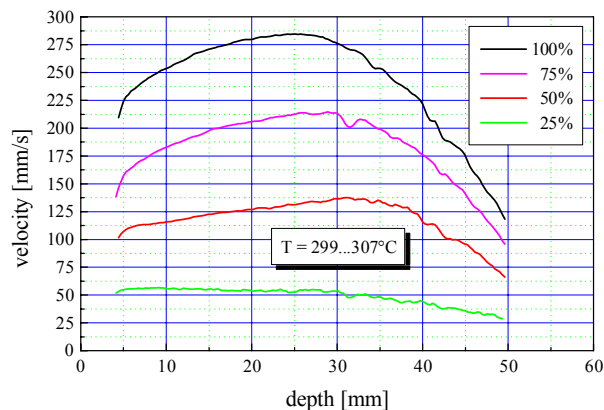


**Figure 4. Schematic view of the integrated ultrasonic transducer**



**Figure 5. Schematic view of the arrangement of the PbBi experiment at FZK**

Stable velocity signals could be received during a period of about 72 hours at temperatures between 180°C and 350°C. Velocity profiles have been obtained at different temperatures for variations of the liquid flow rate (see Fig. 6).



**Figure 6. Measuring results obtained at temperatures of about 300°C for variations of the liquid flow rate (parameter: power of the electromagnetic pump)**

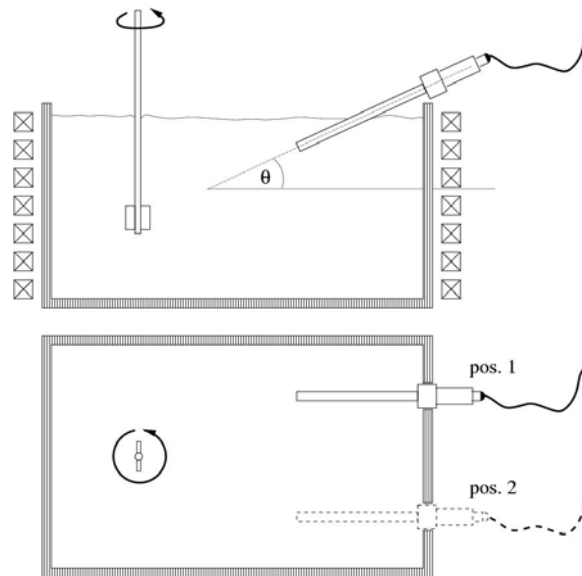
### 2.3 Measurements in CuSn

Another demonstration was done in a flow of a CuSn alloy (Cu35Sn65,  $T_{\text{melt}} = 550^\circ\text{C}$ ) at a temperature of about 620°C. The liquid metal was molten inside a rectangular alumina crucible ( $130 \times 80 \text{ mm}^2$ ) by means of an inductive heating system. The depth of the melt was about 40 mm. The melt temperature was controlled using a bolometer. As shown in Fig. 7 the integrated sensor was dipped into the metallic alloy through the free surface with an angle of 35° with respect to the horizontal line. A mechanical stirrer was used to generate a flow.

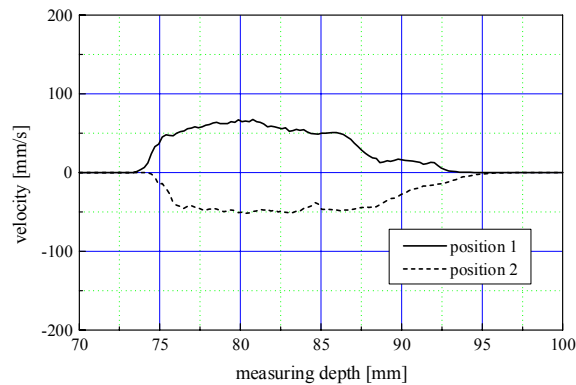
Results obtained from this experiment are shown in Fig. 8. The velocity profiles determined at both measuring positions are similar with respect to the shape and the amplitude and show different signs in accordance with the chosen rotation direction of the mechanical stirrer. Several repetitions of the measurements showed the reproducibility of the results.

## 3. CONCLUSIONS

It has been demonstrated that UDV can be used successfully to determine velocity profiles in metallic melts at high temperatures up to 600°C. The application of acoustic wave guides is shown as a promising way to overcome the thermal restriction of US transducers.



**Figure 7. Schematic view of the arrangement of the CuSn experiment at FZR**



**Figure 8. Velocity profile measured in the CuSn melt at both sensor positions**

The developed integrated sensor delivered clear signals leading to reproducible results. This approach may open a new field for applications of UDV. On the other hand, with UDV a powerful measuring technique could be available for investigations of the velocity structure in liquid metals improving the poor situation for such kind of opaque fluids. However, besides the high temperatures some other problems have to be taken into consideration for liquid metal applications such as the wetting problem, the handling of the oxide layers or chemical reactions between the wave guide material and the metallic melt.

## REFERENCES

- Brito D., Nataf H.-C., Cardin, Aubert J., Masson J.P.** (2001). *Ultrasonic Doppler Velocimetry in liquid gallium*, Exp. Fluids 31: 653-663
- Eckert S., Gerbeth G.** (2002). *Velocity measurements in liquid sodium by means of ultrasound Doppler velocimetry*, Exp. Fluids 32: 542-546
- Moreau R.** (1990). *Magnetohydrodynamics*, Kluwer Academic Publisher, Dordrecht
- Takeda Y.** (1987). *Measurement of velocity profile of mercury flow by ultrasound Doppler shift method*, Nucl. Techn. 79: 120-124