

AN AZIMUTHAL-STREAMWISE STRUCTURE OF AN AXISYMMETRIC SUDDEN EXPANSION FLOW

Noriyuki Furuichi¹, Ikutaro Yamashita¹, Masaya Kumada¹ and Yasushi Takeda²

¹ Gifu Univ. 1-1 Yanagido, Gifu, 501-1193, Japan, e-mail:furuichi@cc.gifu-u.ac.jp

² Hokkaido Univ., Kita 8, Nishi 5, Kita-ku, Sapporo, 060-0808, Japan, e-mail:yft@eng.hokudai.ac.jp

Keywords: Separation, Reattachment, Azimuthal Structure, Axisymmetric Sudden Expansion, Proper Orthogonal Decomposition

ABSTRACT

An azimuthal-streamwise velocity field was obtained by UVP method using multiple transducers and a streamwise variation of the averaged velocity field, correlation coefficient and eigenvalue spectra decomposed by a proper orthogonal decomposition will be discussed. Several typical inflection points were found in the streamwise variations and a coherent structure was found relating to a large-scale fluctuation around the reattachment region.

1. INTRODUCTION

An objective of this study is to clarify an azimuthal structure of a flow in an axisymmetric sudden expansion. The sudden expansion flow is one of the most popular flow fields involving a separation and reattachment phenomenon. The geometry of the configuration is simple and an analysis has been made, as in the pervious researches, as a two-dimensional field. It is, however, well known that three-dimensional structure exists in this flow field by experiments (ex. Kasagi et al.,1977, Troutt et al.,1984, Hijikata et al., 1991) and by numerics (Neto et al.,1993, Le et. al,1997). We also observed a spanwise structure around a reattachment region of a two-dimensional backward-facing step using UVP (Furuichi and Kumada, 2002) by a spatio-temporal measurement of a spanwise velocity component.

A vortex shedding from the separated shear layer is deformed largely around the reattachment region and causes a reattachment phenomenon. Furthermore, as it is indicated that the flow does not fully recovered at 20 times step-height at downstream (Le et al, 1997), the velocity field is affected by the separation and reattachment with the deformation process even in the wake. The three-dimensional structure as mentioned above might have a strong relationship with the deformation process. Therefore, it is necessary to observe the velocity field on the streamwise-spanwise (azimuthal) direction in order to clarify the three-dimensional structure and analysis by some decomposition methods.

In this paper, the flow field is an axisymmetric sudden expansion; a flow which shows separation and reattachment and eliminates a side wall effect. We obtained the velocity field at various azimuthal angles by using multiple transducers and observed the streamwise velocity component in azimuthal-streamwise plane and temporal field. We will discuss the streamwise variation of the averaged velocity field and of an azimuthal coherent structure by using correlation method and proper orthogonal decomposition.

2. EXPERIMENTAL APPARATUS

A test section of the experimental apparatus with transducers and coordinate system are illustrated in Figure 1. The pipe diameter of upstream is $d=25\text{mm}$ and that of downstream is $D=45\text{mm}$ (Expansion ratio is 1.8, step height h is 10mm). The bulk velocity in the upstream channel is fixed at $V_b=0.152\text{m/s}$ and Reynolds number is $Re_d=3820$. The sudden expansion is

positioned at $85d$ downstream from the flow conditioner and the inlet flow is fully developed. All transducers were set outside of the step wall at $r/h=1.75$ (the centre of the step) to obtain the velocity profile $v_z(z,t)$. The velocity profile was obtained at $z/h=2\sim 20$ with channel distance 1.48mm . In this experiment, we used seven transducers positioned from $\theta=-\pi/2$ to $\pi/2$ with the increment of $\pi/6$ as shown in the figure. We obtained the pseudo velocity field as $v_z(z,\theta,t)$ by switching transducers using a multiplexer. A measuring interval per one transducer is 21ms and one of a series is 147ms .

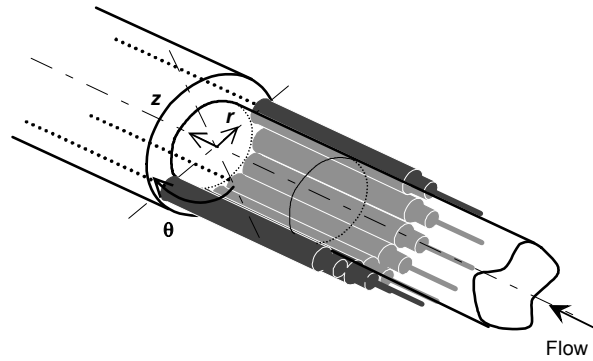

Figure 1. Experimental apparatus and arrangement of transducers

3. RESULTS AND DISCUSSION

3.1 Velocity field

A mean velocity profiles and turbulent intensity profiles at various streamwise positions are shown in Figure 2. As shown in the figure, the both profiles with respect to the azimuthal direction is not uniform except around the redeveloping region ($z/h>18$), although the difference of the velocity at each azimuthal position is small (i.e. maximum is $0.05V_b$ at $z/h=5.5$). Armaly et al.(1983) measured the spanwise velocity profile of streamwise component and showed that it is not uniform at $Re=3000$. Furuichi and Kumada (2001) also showed the same tendency concerning the spanwise velocity component of the two-dimensional backward-facing step. We have no knowledge of the azimuthal velocity profile in the previous paper, however, it is clearly shown that the axisymmetric backward-facing step should not be treated as two-dimensional structure even the mean velocity field, especially around the reattachment region.

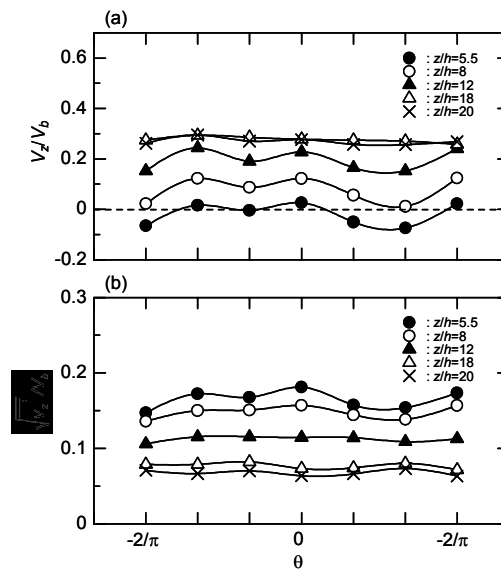

Figure 2. Mean profiles of (a) mean velocity (b) turbulent intensity at variable streamwise positions

An example of an pseudo-instantaneous velocity field of $v_z(z,\theta)$ is shown in Figure 3. The shaded region shows negative velocity, the white is zero and the gradation becomes darker with increasing velocity. The azimuthal variation of the zero region is not uniform with respect to the spanwise direction and the recirculation region shows a complex structure interfered with the separated shear layer. The large-scale structures can be observed $z/h>10$. The scale of it $z/h\approx 10$ is $\Delta\theta<\pi/2$ as shown (a). At further downstream, it grows larger to $\theta\approx\pi/2$ as shown (b).

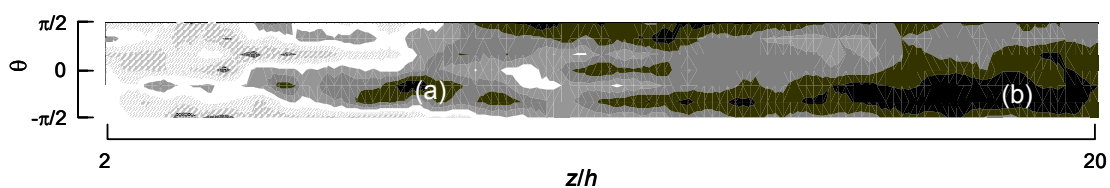

Figure 3. Example of an instantaneous velocity field of $v_z(z,\theta)$

3.2 Cross-correlation

The variation of a cross-correlation coefficient $R_{vv}(z, \theta_1, \theta_2)$ is shown in Figure 4. The subscript 1 and 2 mean the azimuthal measuring points and the $\Delta\theta$ shown right hand in the figure is the angle between θ_1 and θ_2 . The positive correlation coefficient is observed up to $\Delta\theta=2\pi/3$ over the measuring region. The length scale of azimuthal direction $L_\theta/\pi=0.41$ at $z/h=8$ and $L_\theta/\pi=0.48$ at $z/h=18$. This result is reasonable result as shown in Figure 3. The streamwise variation has some inflection points as shown the dotted line in the figure, if one observes more detail. Although it shows a complex variation around a zero-cross point because of an interaction between the recirculation flow and shear flow, the local minimum can be observed clearly at $z/h=8$. Troutt et al.(1984) shows also the local minimum around a reattachment region and they supposed that it is caused by the interaction of the wall surface and large-scale vortices. At $\Delta\theta < \pi/3$, the correlation coefficient increases with the streamwise position, while, at $\Delta\theta > \pi/2$, it shows local maxima at $z/h \approx 12$ and decreases with the position. At downstream of this region, the turbulent intensity profile as shown in Figure 2 becomes uniform with respect to azimuthal direction. Further downstream, after it shows the local minimum at $z/h=16$, it increases linearly with the streamwise position. Since the variation with azimuthal direction becomes weaker as shown in the mean velocity field, the scale of the eddy might becomes larger in this region. It should be noted that the tendency of the correlation coefficient does not saturate even at $z/h=20$. It is indicated that the flow does not fully recovered as indicated by Le et al.(1984).

3.3 POD decomposition

To observe the streamwise variation of spanwise structure as shown in Figure 4 from another viewpoint and identify the coherent structure of this flow field, the velocity field was decomposed by the POD (Proper Orthogonal Decomposition) method. The streamwise variation of eigenvalues of the velocity field $v_z(\theta, t)$ is shown in Figure 5. This result also shows a little change in the variation curve. The first mode shows an almost linear increase with the streamwise position except $z/h < 6$ (in the recirculation region). The mode which shows a typical change is the second and third mode at $z/h=8, 12, 16$ as similar with the one of correlation coefficient. It is suggested that the inflection point around the zero-cross point is related to

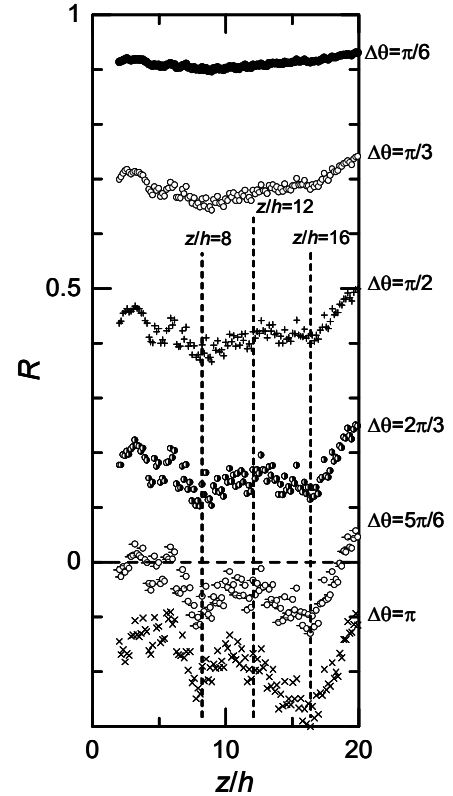

Figure 4. Variation of the correlation coefficient

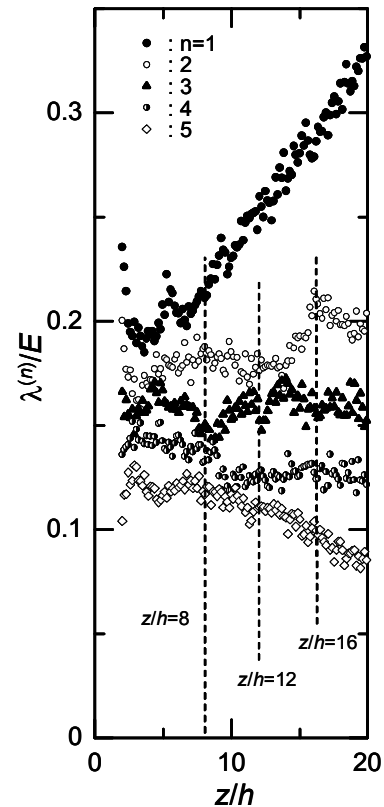

Figure 5. Streamwise variation of eigenvalues

the variation of third mode and the redeveloping region is related to the second mode.

Examples of the decomposed velocity field which were composed of the first and second eigenvectors are shown in Figure 6. The figure (a) is $z/h=6$, which corresponds to the zero-cross point and (b) is $z/h=16$. The solid line is the contour line for $v_z'/V_b=0.05$ and the dotted line is for $v_z'/V_b=-0.05$. In the figure (a), a certain coherent structure can be observed as a streak structure with a period of $fh/V_b \approx 0.03$, of which the width is $\theta \approx \pi/4$ and flow direction changes alternately in azimuthal direction although it is broken around $tV_b/h=140$. The time length of the streak observed as the contour line $v_z'/V_b=0.05$ is about 35 in dimensionless time. This coherent structure shows non-stationary behaviour with respect to azimuthal direction and it fluctuates within $\theta \approx \pm\pi/6$ as shown by the dotted arrow in the figure. Thus, we found the coherent structure fluctuating with respect to the azimuthal direction around the separated shear layer. It was pointed out that the large-scale fluctuation of $fh/V_b \approx 0.05$ (Furuichi and Kumada, 2002) is dominant around the reattachment region concerning a flapping motion of the separated shear layer. It is suggested from the figure (a) that the large-scale fluctuation is related to the fluctuation of azimuthal direction as the coherent structure. On the other hand, in the wake around $z/h=16$ as shown in figure (b), it is found that the coherent structure can not be observed, although the structure becomes larger.

4. CONCLUSION

The azimuthal-streamwise velocity field was obtained by the UVP method using multiple transducers and we discussed about the streamwise variation of the averaged velocity field, correlation coefficient and eigenvalues decomposed by the proper orthogonal decomposition. The typical inflection point was found in the variation of streamwise structure. Furthermore, the coherent structure was found around the zero-cross point relating to the large-scale fluctuation.

REFERENCES

- Armaly, B.F., Durst, F., Pereira, J.C.F. and Schonung, B., J. Fluid Mech., 127, 1983, 473-496
 Furuichi, N. and Kumada, M., Exp. in Fluids, 32, 2002, 179-187
 Hijikata, K., Mimatsu, J. and Inoue, J., ASME-FED Experimental and Numerical Flow Visualization, 128, 1991, 61-68
 Kasagi, N., Matsunaga, A. and Yokobori, S., Proc. The International Symposium on Flow Visualization, 1977, 245-250
 Le, H., Moin, p. and Kim, J., J. Fluid Mech, 330, 1997, 349-374
 Neto, A.S., Grand, D., Metais, O. and Lesieur, M., J. Fluid Mech., 256, 1993, 1-25
 Troutt, T.R., Scheelke, B. and Norman, T.R., J. Fluid Mech., 143, 1984, 413-427

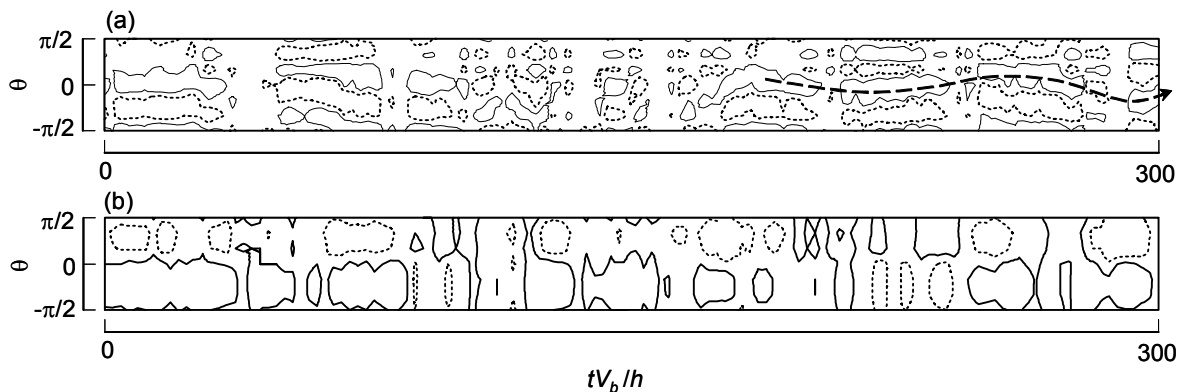

Figure 6. Examples of reconstructed velocity field of $v_z(\theta, t)$ by the first and second eigenvectors at (a) $z/h=6$ (b) $z/h=16$.