

OPTIMISATION OF UVP MEASUREMENTS USING NEW TRANSDUCER TECHNOLOGY AND ADVANCED SIGNAL PROCESSING TECHNIQUES

Reinhardt Kotzé^a, Johan Wiklund^b and Rainer Haldenwang^a

^aFPRC - Flow Process Research Centre, Cape Peninsula University of Technology, PO Box 652-Cape Town, South Africa

^bSIK – The Swedish Institute for Food and Biotechnology, PO Box 5401-Gothenburg, Sweden

Studies have suggested that the accuracy of the measured velocity gradient close to pipe walls need to be improved. In order to increase the accuracy of velocity measurements close to wall interfaces a specially designed delay line transducer was acoustically characterised and evaluated. Velocity profiles measured using the delay line transducer, were initially distorted due to the effect of finite sample volume characteristics and propagation through the delay line material boundary layers. These negative effects were overcome by measuring physical properties of the ultrasonic beam and implementing a newly developed deconvolution procedure. The optimised UVP system was evaluated and compared to standard transducers and commercial software in a straight pipe (16 mm) for three different non-Newtonian fluids. The combination of the signal processing techniques and new transducer technology reduced previous problems and was found to be essential for accurate in-line process and quality monitoring within industrial applications.

Keywords: Ultrasonic Velocity Profiling, ultrasonic transducer, deconvolution, acoustic characterisation

1 INTRODUCTION

UVP is an ideal technique for flow behaviour measurements in a wide range of industrial applications since it is non-invasive, works with opaque fluid systems, inexpensive, and easy to implement relative to other velocity profile measurement methods [1-2]. The UVP technique has been evaluated in a wide range of model and industrial fluid suspensions, ranging from paper pulp, mineral suspensions, fat crystallisation, liquid metals and more, see e.g. [3-4]. However, there are still a few problems remaining with the current UVP instrumentation and methodology in order to achieve the robustness and accuracy required in industrial environments. These problems include, depending on the installation method, distortion caused by cavities situated in front of ultrasonic transducers, measurement volumes overlapping wall interfaces, refraction of the ultrasonic wave (Doppler angle changes), sound velocity variations as well as physical changes of the ultrasonic beam shape and intensity [5-6]. Such negative effects influence the effectiveness of using UVP within industrial applications such as in-line process monitoring, rheology (UVP+PD) and flow visualisation. The main objective of this research work was to optimise the UVP system for accurate complex flow measurements by evaluating a specially designed delay line transducer and implementing advanced signal processing techniques. Results were compared with that obtained using the existing standard UVP system as well as using the new delay line transducer combined with new software. These were also compared to theoretical velocity profiles obtained using tube viscometry data.

2 THEORY

2.1 Non-Newtonian flow

The equation for the Herschel-Bulkley model is as follows:

$$\tau = \tau_y + K(\dot{\gamma})^n, \quad (1)$$

where K , n and τ_y are three empirical curve-fitting parameters [7]. Eq. 1 can be integrated to give the radial velocity (v) profile [7]:

$$v = \left(\frac{n}{(1+n)} \right) \left(\frac{\Delta P}{2LK} \right)^{\frac{1}{n}} \left((R - R_{plug})^{1+\frac{1}{n}} - (r - R_{plug})^{1+\frac{1}{n}} \right). \quad (2)$$

It will be noted that the Herschel-Bulkley model can easily be modified to describe the power-law and Bingham plastic models [7]. Slatter and Lazarus [8] formulated a Reynolds number (Re_3) for non-Newtonian pipe flow and this number was used as an indication of the flow regimes during tests conducted in this work.

2.2 Deconvolution of velocity profiles

Velocity profiles are generally not known with sufficient accuracy as a result of the effect of the finite sample volume characteristics and propagation through solid boundaries or wall material layers [9]. Mathematically simplified, the measured Doppler profile (V_m) can be described as a one-dimensional convolution integral:

$$V_m = \int_0^r V_t(x) \cdot I(r-x) dx, \quad (3)$$

where V_t is the 'true' velocity profile and I the sample volume intensity distribution. Since, V_m and I are known, one can now apply a deconvolution

process in order to obtain the correct velocity profile (V). The basic deconvolution algorithm is shown, in block diagram form, in Fig. 1.

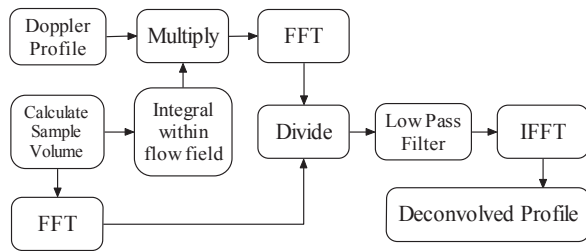

Figure 1: Deconvolution algorithm [9].

More information on deconvolution procedures and test setups for characterising sample volumes as well as UVP systems can be found in Jorgensen and Garbini [10] and Walker *et al.* [11].

3 MATERIALS AND METHODS

3.1 Materials

Carboxy Methyl Cellulose (CMC) was tested and is generally regarded as an ideal non-Newtonian power-law fluid for experimental work [5]. The CMC (Protea Chemicals, Bryanston, South Africa) solution used was 7% w/w. Bentonite powder (Protea Chemicals) was mixed with water to obtain different concentrations of bentonite:water suspensions. The concentration tested was 6.9% w/w. Dry kaolin powder (Protea Chemicals) was used to prepare a kaolin:water suspension of 17% v/v. Kaolin suspensions attenuate the ultrasonic energy significantly [5] and was thus used to test the limitations of the optimised UVP system.

3.2 Experimental flow loop UVP instrumentation

The experimental setup consisted of three pipes (9, 16 and 28 mm) which were connected to a 100 mm progressive cavity positive displacement pump with variable speed drive (maximum volumetric flow 11 l/s) to enable tests at different flow rates. Each line is also fitted with an electromagnetic flow meter (Krohne OptiFlux 4000, Gauteng, South Africa) to measure the flow rate. Pressure measurements were conducted over a set distance using high (130 kPa) and low (6 kPa) range differential pressure sensors (Danfoss, Cape Town, South Africa). In addition, the relative density and temperature of the slurries are measured with a mass-flow meter (MassFlo 6000, Danfoss-Siemens, Cape Town, South Africa). Procedure and method for obtaining accurate in-line experimental data as well as post data analysis is discussed in detail by Chhabra and Richardson [7]. A specially designed flow adapter for ultrasonic transducer installation [2-6] and housing was installed on the 16 mm pipe for flow measurements. Fig. 2 shows a schematic diagram of the pipe rig including the ultrasonic equipment fitted onto the 16 mm pipe.

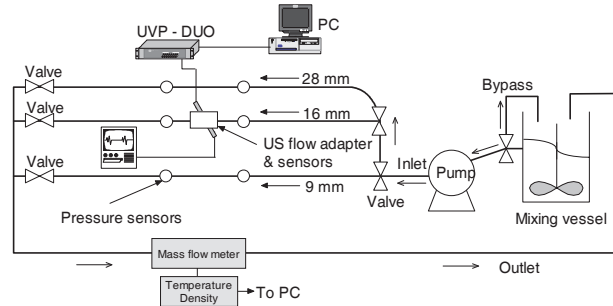

Figure 2: Schematic illustration of the pipe rig at FPRC.

In this work the latest UVP instrument (UVP-DUO-MX, Met-Flow SA, Lausanne, Switzerland) was used for velocity profile measurements. Doppler, Immersion type 4 MHz, 5 mm active element standard and delay line ultrasonic transducers were used. Fig. 3 shows a schematic diagram of the flow adapters with standard and delay line transducers. More information on the delay line transducers can be found in Kotzé *et al.* [5].

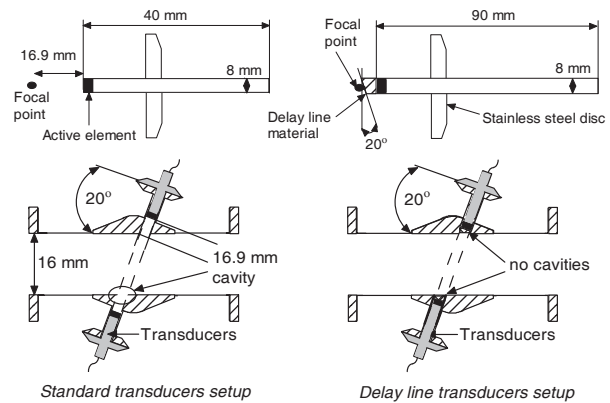

Figure 3: Standard and delay line transducers and installation setup [9].

3.4 Acoustic characterisation of transducers

For acoustic characterisation tests a high performance needle hydrophone (Precision Acoustics Ltd, 1 mm piezoelectric crystal) setup was used in combination with a high precision (± 0.03 mm) robotic arm (KUKA Robotics GmbH). Two ultrasonic transducers were tested: one delay line transducer and one standard transducer. The transducer was moved in a two-dimensional field from the centre of the needed hydrophone using the robotic arm. This enabled measurement of a range of acoustic intensities in increments of 0.1 mm in the Y direction and 1 mm in the X direction (see Fig. 4), which gave a complete acoustic map of the transducer. Tap water was used throughout all the tests and the temperature was continuously monitored using a temperature sensor submerged in the tank. A complete Graphical User Interface (GUI) was written in Matlab® to control the robot arm using a RS232 interface between the robot controller box and PC. An Agilent 100 MHz digital

oscilloscope (Model 54622A) with RS232 connectivity to a PC was used to record the data.

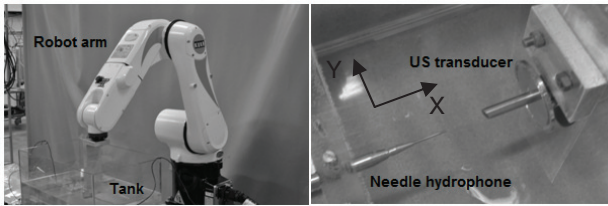

Figure 4: Acoustic characterisation using needle hydrophone and robot setup [5].

4 RESULTS AND DISCUSSION

4.1 Acoustic characterisation

Fig. 5 shows the complete acoustic map for the delay line transducer using the needle hydrophone setup. The results were interpolated in order to produce a more detailed representation of the acoustic field. The colour bar positioned at the right shows the intensity values in voltage (V). An excitation voltage of 150V was selected for these tests due to the design of the transducers.

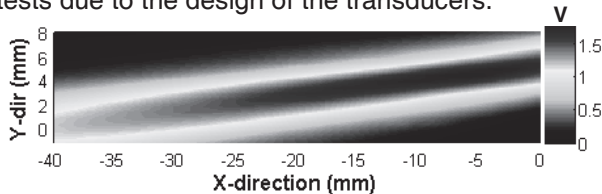

Figure 5: Acoustic map of delay line transducer.

Firstly it can be observed that the acoustic field of the transducer is fixed at an angle (with respect to the transducer). The angle with respect to the transducer was determined at 7.4 degrees. Also, notice that the focal point of the delay line transducer is situated just beyond the delay line material, which means no velocity measurements are taken within the near-field, where the acoustic pressure field is irregular. When results are compared to the standard transducer the standard transducer's signal intensities (see Fig. 6) are ± 1.5 times higher, showing that there is a loss of energy, possibly caused by the delay line material.

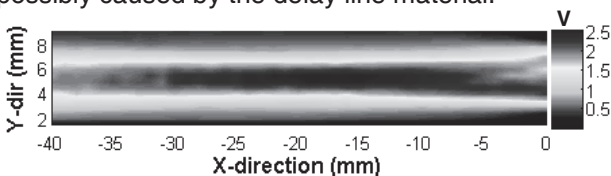

Figure 6: Acoustic map of standard transducer.

In this case the acoustic beam direction is parallel with respect to the transducer. The focal point of the standard transducer seems to be at around 10 mm from the surface.

4.3 Velocity profile measurements

Velocity profiles obtained using the delay line transducers are presented before and after

implementing the deconvolution procedure. Fig. 7 shows profiles measured in a 16 mm pipe using a standard and delay line transducer for CMC 7% w/w ($K = 1.43$, $n = 0.67$) at a bulk flow rate of 0.141 l/s ($Re_3 = 988$). Note the significant distortion of the measured velocity profile (crosses) due to averaging effects across the finite sample volume in the flowing liquid medium (see Sec. 2.2). A major improvement between the results obtained using the delay line transducer after deconvolution (circles) can be observed. A theoretical velocity profile (Eq. 2) was also plotted for comparison (using the tube viscometer data). The difference in magnitude between the profiles measured using the standard and delay line transducer was due to slight variations in flow during the measurements. Also, note from Fig. 5 that the Doppler angle had to be corrected due the angle refraction caused by the delay line material. The most important observation here is the increase in velocity at the pipe wall for the profile measured using the standard transducer (shown by diamonds). Here the effect of the cavity (Fig. 3) is more pronounced even for a power-law fluid where the velocity gradients are not high.

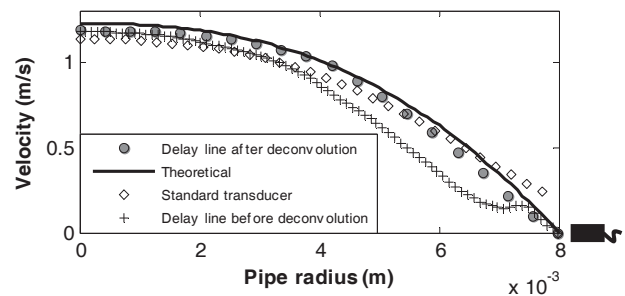

Figure 7: Comparison of profiles for CMC 7% w/w.

Fig. 8 shows a comparison of velocity profiles measured in bentonite 6.9% w/w ($K = 0.006$, $n = 1$, $\tau_y = 9$) at a flow rate of 0.4 l/s ($Re_3 = 1900$). In the case of measuring in fluids with a yield stress the cavity distorts profiles (diamonds) more significantly due to the high velocity gradients present close to the pipe walls. When comparing the profiles before and after deconvolution (crosses and circles), it can be seen that the deconvolution procedure improved the velocity data close to the wall significantly.

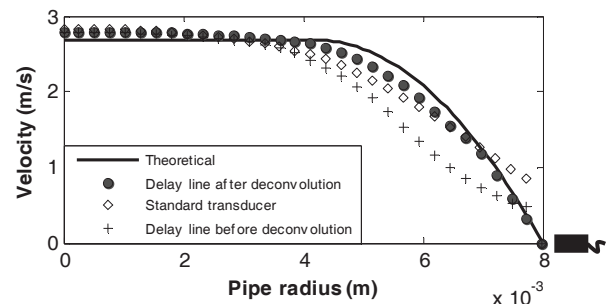

Figure 8: Comparison of profiles for bentonite 6.9% w/w.

The velocity profiles shown after implementing the deconvolution procedure also show better

agreement with the theoretical profiles. Velocity profiles measured in kaolin 17% v/v ($K = 0.54$, $n = 0.47$, $\tau_y = 16.77$) at a flow rate of 0.2 l/s ($Re_3 = 330$) are shown in Fig. 9. Due to the attenuating properties of the kaolin suspensions, it was not possible to measure velocity profiles using a standard transducer.

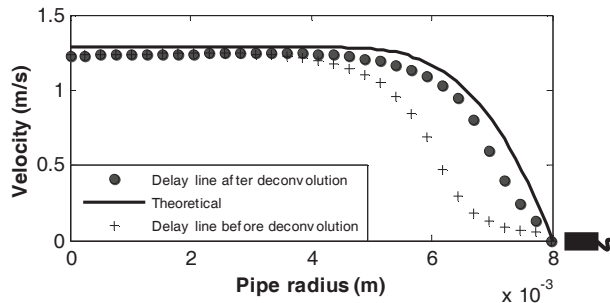

Figure 9: Comparison of profiles for kaolin 17% v/v.

According to the acoustic measurements of the different transducers (Sec. 4.1), the standard transducers generated more acoustic energy than when compared to the delay line transducer. However, due to the cavity between the standard transducer's surface and pipe wall (Sec. 3.2), which was filled with the test fluid, most of the energy was absorbed before the ultrasonic pulse can propagate across the pipe diameter, see Fig. 10. In this case the delay line transducer could measure profiles in this particular fluid as the only material (which also absorbs energy) between the wall interface and transducer surface is the actual delay line material and not the attenuating test fluid. As shown before, the deconvolution procedure improved the velocity data close to the wall significantly.

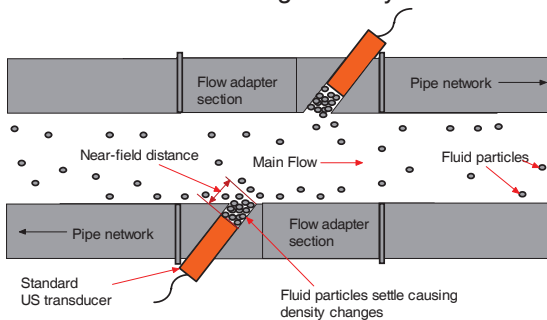

Figure 10: Fluid particles settling inside cavities with standard transducer installation setup [5].

5 CONCLUSIONS

A new type of ultrasonic transducer for velocity profile measurements in industrial applications was developed and tested. The new transducer technology was demonstrated to have superior accuracy and eliminated all existing problems with erroneous velocity data close to the wall. It has been shown how erroneous velocity data due to the finite size of the sample volume can be removed using a deconvolution procedure. Despite the improved accuracy, deconvolution has not been widely used

in the medical field. Also, to the authors' knowledge, it is believed that this concept has never been applied for measurements in the fluid engineering industry before. This may be a result of its complexity and because it has not been evaluated for different materials and under a full range of flow conditions. In conclusion, the UVP technique has been optimised by using new transducer technology and advanced signal processing techniques. The overall improvement will, for the first time, enable detailed flow behaviour measurements for industrial applications, especially for in-line rheometry and process monitoring. Furthermore, the improved methodology will enable more accurate verification of theoretical simulations for complex flow in different geometries.

ACKNOWLEDGEMENTS

The NRF of South Africa, CPUT and Vetenskapsrådet – The Swedish Research Council, Research Links, for funding. SIK is gratefully acknowledged for scientific collaboration.

REFERENCES

- [1] Takeda Y: Measurement of velocity profile of mercury flow by ultrasound Doppler shift method, Nucl. Technol. 79 (1987), 120-124.
- [2] Wiklund J, Shahram I, Stading M: Methodology for in-line rheology by ultrasound Doppler velocity profiling and pressure difference techniques, Chem. Eng. Sci. 62 (2007) 4159-4500.
- [3] Wiklund J, Stading M: Application of in-line ultrasound Doppler based UVP-PD method to concentrated model and industrial suspensions, Flow Meas. Instrum. 19 (2008) 171-179.
- [4] Kotzé R, Haldenwang R, Slatter P: Rheological characterization of highly concentrated mineral suspensions using an Ultrasonic Velocity Profiling with combined Pressure Difference method, Appl. Rheol. 18(6) (2008) 62114.
- [5] Kotzé R, Wiklund J, Haldenwang R: Optimisation of Pulsed Ultrasonic Velocimetry and Transducer Technology for Industrial Applications, Ultrasonics, (2012) (Accepted)
- [6] Kotzé R, Wiklund J, Haldenwang R, Fester V: Measurement and analysis of flow behaviour in complex geometries using the Ultrasonic Velocity Profiling (UVP) technique, Flow Meas. Instrum. 22 (2011) 110-119.
- [7] Chhabra RP, Richardson JF: Non-Newtonian Flow and Applied Rheology: Engineering Applications, Oxford, Great Britain: Butterworth-Heinemann (2008).
- [8] Slatter PT, Lazarus JH: Critical flow in slurry pipelines. British Hydromechanics Research Group, 12th Int. Conf. Slurry Handling & Pipeline Transport, (1993) 639-654.
- [9] Kotzé R, Haldenwang R: Development of an ultrasonic in-line rheometer: Evaluation, optimisation and verification, 15th Int. Conf. Transport & Sedimentation Solid Particles, 15 (2011) 49-61.
- [10] Jorgensen JE, Garbini JL: An Analytical Procedure of Calibration for the Pulsed Ultrasonic Doppler Flow meter, J. Fluid Eng. 96 (1974) 158-167.
- [11] Walker AR, Phillips DJ, Powers JE: Evaluating Doppler Devices Using a Moving String Test Target, J. Clin. Ultrasound, 10 (1982) 25-30.